



AsiaFlux Newsletter

Contents

New Year's Greetings Joon Kim, Akira Miyata, and Guirui Yu	1
Report of the AsiaFlux Workshop 2009-Integrating Cross-scale Ecosystem Knowledge: Bridges and Barriers Kentaro Takagi and Workshop Organizing Committee	2
Launch of NCAM as Advanced Agro-Meteorological Framework Byonglyol Lee	6
A Short Report on "East-Asia Workshop on Climate Change" Hyojung Kwon.....	7
Carbon Flux Data Computing and Sharing Using Ecoinformatics Techniques Chau-Chin Lin and Yue-Joe Hsia	9

New Year's Greetings

Joon Kim, Akira Miyata, and Guirui Yu
Chair & Vice-chairs of AsiaFlux

Happy New Year! The year 2009 has been fruitful as reflected in our newsletters and we are excited to begin 2010. Have you made your New Year's resolutions? If not, it is never too late since for most of us in Asia, Lunar New Year is yet to come!

According to a review by Laurie Sontag, the top ten New Year's resolutions are in alphabetical order: (1) become a better person, (2) become more organized, (3) be more patient at work and with others, (4) eat better, (5) exercise more, (6) find a better job, (7) lose weight, (8) save more money, (9) stick to a budget, and (10) stop smoking.

While most of them are rather personal goals, we, AsiaFlux, as a science community, can also use the concept of new year resolution so that we may (1) become a better community, (2) become better organized, (3) volunteer more to serve others, (4) collaborate more rigorously, (5) reach out to learn and teach, (6) join one of the five Workgroups (i.e., Measurement Standards, Data Management & Policy, Synthesis & Assessment, Short Course, and ACTSociety), (7) reprioritize goals and tasks, (8) build resilience and adaptive capacity, (9) stick to our vision cast in 2008, and (10) never stop 'flux'ing.

Our vision has not changed but has been refined, i.e., to serve as science frontier - the agora for ecosystem science, service and stewardship through developing and transferring knowledge characterized by consilience, contextualization, and cultural diversity. According to Albert Einstein, "*We shall require a substantially new manner of thinking if mankind is to survive.*" To pursue our vision, we have set two ambitious short-term goals: (1) to assess, synthesize and publish the first Asian carbon budget (ACB) report and (2) to establish an infrastructure for the Asian Carbon Tracking System (ACTS) through the synergy of theory, measurement, and modeling.

Goals are dreams with deadlines and we want to accomplish these daunting targets by the end of 2011. We have established the ACB task force team to lead such efforts and invite you all to join the agora where we synthesize and contextualize scientific knowledge by welcoming diversity, tolerating uncertainty, and embracing paradox. T.S. Eliot once said, "*Only those who will risk going too far can possibly find out how far one can go.*" So, as Les Brown encourages, why don't we shoot for the Moon? Even if we miss, we'll land among the stars!



Report of the AsiaFlux Workshop 2009 Integrating Cross-scale Ecosystem Knowledge: Bridges and Barriers

Kentaro Takagi and Workshop Organizing Committee
Hokkaido University, Japan

8th AsiaFlux Workshop was held on 27-29 October, 2009 at Hokkaido University in Sapporo, Japan (Fig. 1). This workshop was sponsored by Japan Society for Promotion of Science, National Natural Science Foundation of China, National Research Foundation of Korea, Global COE Program (Establishment of Center for Integrated Field Environmental Science)-MEXT-Japan, Japan Aerospace Exploration Agency (JAXA), National Institute for Environmental Studies, LICOR Biosciences, Meiwafoods Co. Ltd., Campbell Scientific Inc., and Sapporo International Communication Plaza Foundation, and organized in cooperation with Society of Agricultural Meteorology of Japan, iLEAPS Japan, and Japan Long-Term Ecological Research Network. More than 180 scientists and students took part in the workshop from 16 countries and regions, and we had 36 oral and ca. 100 poster presentations. JAXA award for AsiaFlux Workshop2009 was established for young scientists in Asia in the field of remote sensing, and two winners were invited to the workshop with support of their travel costs.

With increasing interests in the global change issues, we are compelled to expand our views to the global biogeochemical context through collaboration with other networks of research under the framework of Earth observing system, and offer the right scientific knowledge to society to answer socio-economic questions. In this context, the workshop was organized in order to explore the advantages of collaborations between flux research community and various other research communities specializing particularly in long-term ecological research, remote-sensing, and social science to 1) deepen our knowledge about ecosystems, 2) extend our knowledge to broader regions, and 3) extend the knowledge to the society. For this purpose, we organized special sessions “Bridges between Ecosystem Observation and Remote Sensing”, “Global Biogeochemical Cycles”, and “Interfaces between Carbon Science and Society” that feature collaborations with other networks, such as iLEAPS, ILTER and Remote sensing fields. On the other hand, sessions which deal with other fluxes and ecosystem studies or technical issues



Figure 1. Memorial photo



for the flux measurement were still highly requested, so we had “Regular” and “Barriers in Flux Measurements” sessions for this purposes. We also organized a session to share the recent progresses in the flux synthesis studies in Asia under “CarboEastAsia” program. All keynote lectures showed the future directions of the flux studies and there were lively discussions in the poster sessions (Fig. 2). Many participants visited the exhibition booths and discussed with sponsoring companies about new instruments.

As optional programs, we held a young scientist meeting, and two field excursions after the main workshop. Beginning in Taiwan in 2007, this was the third meeting for young scientists. Participants enjoyed communication with invited scientists or other young generation in Asian region. Destinations of excursion A (one day trip, 29th) were FFPRI Sapporo meteorological research site belonging to JapanFlux and Tomakomai Experimental Forest, Hokkaido University, which is one of the Japan long-term ecological research (JaLTER) site. Both sites are severely damaged by a strong typhoon in 2004. Participants were given lectures about the typhoon effect on the forest ecology and biogeochemical cycles, and enjoyed approaching tree canopies using flux towers and canopy crane (Fig. 3). Excursion B (two days trip, 29th-30th) visited two JapanFlux sites, i.e. Sarobetsu mire, where flux observation is on going at a sphagnum bog and an adjacent transition peatland to evaluate the effect of invasion of vascular plants on the carbon, water, and energy budgets, and Teshio Experimental Forest, Hokkaido University, where long-term flux observation is conducted to evaluate the effect of forestry activities on the biogeochemical cycles (Fig. 4). Both sites locate at northernmost Japan (ca. 300 km north from Sapporo and 5 hours by bus). Participants also visited at northernmost point of Japan during the excursion. The workshop organizing committee appreciates the valued many participants and sponsoring companies from all over the world, and the local staffs for the successful management of the workshop.

Opening Session (morning, 27th)

Beginning by welcome addresses from the chairs of AsiaFlux and Local organizing committee, 7 representatives from regional networks in Asia (ChinaFLUX, India, JapanFlux, KoFlux, OzFlux, Taiwan, and ThaiFlux) reported their recent progresses. ThaiFlux has 4 natural forest, 3 artificial forest, and 6 agricultural field sites. They are planning to have a training course



Figure 2. Oral session



Figure 3. Approaching tree canopies using canopy crane (Ex.A)



Figure 4. Young larch plantation (Ex.B)



for flux researches. Taiwan has 5 forest sites at complex terrains, and they are planning to develop an automated data transfer and calculation system. Indian Council of Forestry Research and Education (ICFRE) is constructing flux observation network for several forest sites in India. OzFlux (Australia and New Zealand) has 11 flux sites, and they emphasized that the evaluation of Net Biome Production, which includes artificial and natural ecosystem degradation has been important for the earth observation. ChinaFLUX, JapanFlux and KoFlux are promoting flux synthesis studies under the framework of the "CarboEastAsia" program.

CarboEastAsia (morning, 27th)

CarboEastAsia is an A3 Foresight Program that has been implemented to support international collaborations among global change scientists particularly from China, Korea and Japan. CarboEastAsia partnership, through synthesizing measurement, theory, and modeling in quantifying and understanding of carbon fluxes and storages in East Asia to cope with climate change protocols, is a true test bed for accomplishing AsiaFlux's vision to serve as the "Science Frontier" by developing and transferring scientific knowledge in carbon, water, and energy cycles in Asia. There were 5 oral and 24 poster presentations in this session. As the keynote lecture, Dr. Reichstein presented recent progresses in the global FLUXNET synthesis activities and concluded that 1) from-point-to-globe is feasible (data uncertainties/problems largely under control), 2) estimated Global GPP and ET are 120 Pg and 60 Eg, 3) precipitation control becoming more important for both GPP and ET, and 4) data derived patterns truly independent from assumptions and complementary to process models. Dr. Lee estimated regional carbon and water budget using WUE obtained at Gwangneung super site in Korea. Dr. Hu evaluated both evaporation and transpiration of four grassland ecosystems in ChinaFLUX using Shuttleworth-Wallace model. Dr. Ichii extracted and analyzed distinct characteristics and anomalies of terrestrial carbon cycle in monsoon Asia during 2001-2006 using AsiaFlux data set and several famous models.

Bridges between Ecosystem Observation and Remote Sensing (afternoon, 27th)

There were 6 oral and 20 poster presentations, and effective and efficient synthesis approaches between ecosystem observation and remote sensing were discussed in this session. Dr.

Nasahara introduced J inter-community (JAXA, JapanFlux, JaLTER, and JAMSTEC) for systematic ecosystem study for effective use of new satellite GCOM-C launched by JAXA in 2014. Two oral presentations by JAXA award winners followed his keynote speech. Dr. Karyanto established permanent ground observation plots for peat observation and evaluated carbon budget of tropical peat swamp forests in Indonesia using the ground observation data and ALOS PALSAR. Dr. Bhattacharya evaluated evapotranspiration rate in Indian agroecosystems using Kalpana-1VHRR, MODIS, and ASTER. Both studies applied adequate remote sensor for their purpose, also established systematic ground observation network for their synthesis studies. Dr. Wingate introduced web camera monitoring network conducted at FLUXNET sites and linked ecosystem phenology obtained using the RGB images with the fluxes.

Barriers in Flux Measurements (morning, 28th)

Flux data are used as a ground truth for remote sensing or model studies, however, still there are uncertainties in the measurements and calculations. Problems in open-path CO₂ flux measurement using LI-7500 and imbalance in energy budget ($H+IE$ vs R_n+G) are discussed in this session (3 oral and 8 poster presentations). As the keynote lecture, Dr. Burba introduced characteristics of LI-7500 and summarized possible causes for the troubles in the observation. Especially, self-heating of the sensor possibly causes the change in the heat environment around the instrument, and special treatment on the calculation of the WPL correction term are required. He also introduced recent progress in the open-path instruments overcoming the problems. Dr. Massman also reported the effect of the self-heating or of the pressure induced flux, $w'p_a'$, on the WPL correction term, and on the estimation of the annual NEE at Glacier Lakes Ecosystem Experiment site in USA, where air temperature decreases to -25°C during winter and high wind dominates all the year round. Self-heating and pressure-induced flux corrections decreases the annual NEP by 4.4-4.8 tC ha⁻¹ in such environment. He also pointed out that the sign of the pressure-induced flux changed within a few seconds in the time lag between w' and p_a' . Dr. Leuning reported that accuracy of the WPL correction term largely depends on the frequency of the fluxes. Their opinions are of one accord in the point that the problems for the open-path CO₂ flux determination are mainly owing to the



application or evaluation of the WPL correction term. Dr. Massman showed that the self-heating correction proposed by Dr. Burba was insufficient in the very cold condition. In order to solve the problem, Drs. Burba and Leuning introduced a trial to convert the open-path instruments into a closed-path one, however, the improvement causes the difficulty in the H₂O concentration fluctuation measurement owing to the high frequency losses of the fluctuation, as the same with the closed-path instruments. In conclusion, both open- and closed path measurements are required, so far, for accurate CO₂ and H₂O flux evaluation.

Global Biogeochemical Cycles (morning, 28th)

Ecosystem carbon and water dynamics must be clarified in the context of the global hydro-biogeochemical cycles. This session focuses on biogeochemical cycles linking carbon and water fluxes, and there were 5 oral and poster presentations. Using global FLUXNET dataset, Prof. Grace showed that boreal and temperate forest NEP is highly correlated with, and enhanced by the nitrogen deposition (Magnani *et al.*, 2007). He suggested that the large discrepancy in the results between obtained by his research group and by previous N deposition experiments (less effective) would be caused by the N application procedure. The deposition occurs on the whole ecosystem in natural environments, although many experiments apply N directly to the soil. He suggested the possibility of direct N absorption by plant canopies, which effectively enhances plant growth, referring many physiological researches. As his lecture, N dynamics have been recognized as an important factor to explain the carbon dynamics in ecosystems, so there were two other oral presentations about this issue. Dr. Hayashi reported ammonia (large N component in the exchange between ecosystems and the atmosphere) exchange rate in a rice paddy field, and Dr. Ren reported N and P concentrations in tree leaves of temperate forests in northern China.

In addition, following two reports attempted to extend FLUXNET data to larger temporal and spatial scales. Dr. Ogée used carbon and oxygen stable isotope composition of tree ring cellulose to estimate long-term ecosystem carbon and water dynamics. Dr. Kim reported the use of FLUXNET data in evaluating phenology, carbon allocation, and growth in the Ent Dynamic Global Terrestrial Ecosystem Model.

Interfaces between Carbon Science and

Society (afternoon, 28th)

This session aims to share the recent achievements on regional carbon flux monitoring studies, with particular emphasis on developing systems to transfer the scientific knowledge to the society, or to develop socio-economic resolutions to prevent and mitigate the risk of human-induced climate change associated with carbon, water and energy cycles in Asia, and there were 3 oral and 4 poster presentations in this session. Prof. Kim, chair of AsiaFlux, emphasized the need of resilience thinking for sustainable ecosystem and society, and showed the vision of AsiaFlux, introducing short-term targets until 2011; 1) providing a report on the Asian carbon (and water) budget with its global perspectives, and 2) developing an infrastructure for Asian carbon (and water) tracking system (ACTS). Prof. Hamanaka showed recent international commitments and political activities on global change issues after Kyoto protocol and introduced ways for a transition to low-carbon society, and expected scientists to support decision-making by quantitative assessment on natural and socio-economic impacts of climate change, and on the mitigation of climate change. Finally, Dr. Hom showed impacts of human-activities, such as land-use change, management, and disturbances on the carbon balance in Baltimore, USA using data obtained at flux sites set along an urban to rural gradient, and reported 500-1000 gC m⁻² year⁻¹ carbon emission by human activities in the city.

Reference

Magnani, Federico, Maurizio Mencuccini, Marco Borghetti, Paul Berbigier, Frank Berninger, Sylvain Delzon, Achim Grelle, Perti Hari, Paul G. Jarvis, Pasi Kolari, Andrew S. Kowalski, Harry Lankreijer, Beverly E. Law, Anders Lindroth, Denis Loustau, Giovanni Manca, John B. Moncrieff, Mark Rayment, Vanessa Tedeschi, Riccardo Valentini, and John Grace, 2007. The human footprint in the carbon cycle of temperate and boreal forests. *Nature*, **447** 849-851.



Launch of NCAM as Advanced Agro-Meteorological Framework

Byonglyol Lee

Korean Meteorological Administration, Korea

The opening ceremony of the National Center for Agro-Meteorology (NCAM) took place at Seoul National University on November 12th. The four related organizations, Korea Meteorological Administration, Rural Development Administration, Korea Forest Service, and Seoul National University, cooperated to found the NCAM to support national food security and advancement of agricultural and forestry services to end-users at national and global levels.

The NCAM will support the sustainable ecosystem management of agriculture and forestry as well as the mitigation of natural disaster exploring the efficient usage of meteorological and climate information as natural resources. It also will provide confronting services to the current global climate change and hopefully lay a foundation for Green Growth.

The NCAM has missions which are to establish the agro-meteorological service system of world level and to accomplish its role as the World Meteorological Organization (WMO) hub center sharing agro-meteorological information and the international training center. The center

will contribute to the nation by integrating the existing agro-meteorological services performed by the individual organizations with higher synergy effect, which will lead to the high value-added information services to the public in the future.

The one of Top 10 Agenda of NCAM is associated with green-house gases (GHG) monitoring, giving emphasis on the fluxes of Carbon and Energy within terrestrial ecosystem to support Asian Carbon Tracking System (ACTS) having been an impending issue in AsiaFlux. As a part of this activity, NCAM has an ambitious plan to strengthen current domestic flux observation network into more stable and better organized structure after reallocation and expansion through close collaboration by the above four institutions. NCAM is willing to support AsiaFlux in diverse subjects in the future, in which more active participation and joint activities can be expected as well as providing information and communication technology (ICT) resources to AsiaFlux.



Figure 1. MoU by four institutions (left) and Inaugural ceremony for NCAM on the 12th Nov. 2009(right) at Seoul National University



A short report on “East-Asia Workshop on Climate Change”

Hyojung Kwon

Yonsei University, Korea

It is easy to feel disappointed by the COP15’s main output during the United Nations Climate Change Conference 2009 in Copenhagen, Denmark. However, the summit lends fresh urgency to challenges in science in order to shape the next round of negotiations. Under the increased emphasis on the continual observation of greenhouse gases and the development of a holistic view through international collaborative research, the 1st “East-Asia Workshop on Climate Change” was opportune.

The workshop was held in Jeju, Korea from Dec. 8 to Dec. 9, 2009, aiming to comprehend the recent status of the greenhouse gases (GHG) monitoring and research, and to build and strengthen collaborative research as a leading science community of climate change in East Asia. About 50 experts in climate change science

from various countries such as China, Japan, Thailand, and Korea participated in the workshop.

The workshop started with the two invited speaker’s lectures: Dr. Kyung-Ryul Kim at Seoul National University, Korea introduced GHG monitoring at Gosan, Jeju in Korea and Dr. Hidekazu Matsueda at Japan Meteorological Research Institute presented the general activities on GHG monitoring in Japan.

The first main session of the workshop was dedicated to Global Atmosphere Watch (GAW) program of World Meteorological Organization (WMO) conducted at various sites in Korea and Japan. Dr. Tae-Young Goo introduced Korean GAW network consisting of three observation sites (e.g., Anmyeon-do, Pohang, and Gosan). Dr. Massaki Ikegami at Japan Meteorological Agency showed how the observation data of GHG can be utilized by an inverse model to



Figure 1. A group photo of the 1st East-Asia Workshop on Climate Change (Courtesy of Tae-Young Goo).



estimate global distribution of carbon dioxide concentration. Dr. Taejin Choi addressed the participating plan of Korea Polar Research Institute to GAW program by implementing the GHG observation at King Sejong station in South Pole. The importance of national measurement standards and international comparison of standard gas for GHG measurement was emphasized by Dr. Jin-Seog Kim at Korea Research Institute of Standards and Science.

The presentations of the second session focused on flux observation from several regional flux measurement networks (e.g., ChinaFLUX, Thailand flux, and KoFlux). Dr. Shaoqiang Wang at Chinese Academy of Sciences introduced ChinaFLUX and its future direction, while Dr. Poonpipope Kasemsap at Kasetsart University presented the flux study conducted in Thailand. Dr. Hyojung Kwon at Yonsei University introduced KoFlux and its current research activities. As a tool of quantifying carbon uptake/release focused on

Asia, CarbonTracker-Asia, was introduced by Dr. Chunho Cho at National Institute of Meteorological Research.

The 1st workshop provided a gathering place (as an *Agora*) on not only GHG monitoring community but also flux measurement community in East Asia to invigorate research cooperation and to promote interdisciplinary studies. With recognition of the importance of continuous collaboration, the 2nd workshop was proposed to be held in Anmyeon-do, 2010. I believe the workshop sets the stage for this initiative collaboration to be mobilized toward even greater collaboration and fruitful productions of climate change in East Asia in the years ahead.



Carbon Flux Data Computing and Sharing Using Ecoinformatics Techniques

Chau-Chin Lin¹ and Yue-Joe Hsia²

¹Taiwan Forestry Research Institute, Taiwan

²National Dong-Hwa University, Taiwan

Today's ecosystem study scientists are facing the challenges to navigate the ever-increasing amount of sensor data collected from a wide variety of environment sensors. The carbon flux tower is one of the environmental sensors which focus on carbon flux data. Scientists use eddy covariance theory to allow the carbon dioxide flux through an ecosystem to be estimated by using sonic anemometer and infrared beam connected to a tower. Ideally, flux scientists should not have to worry about data handling technology. They might only concentrate on analysis tasks, if there is an interoperable system of these sensor data.

However, the reality is the data measured by those equipments from different towers are mostly stored in different databases without a standard data schema and processed with tools using different computer languages have been designed for scientists using their personal computer to do the analyses. The current storing and processing data sets of eddy covariance model are difficult to share and compute using a

wide open tool among different flux net, although they are using the same measurement process. The individual tool using to computing raw data provides well process, but the details from the entire range of analyses conducted are unavailable or undocumented.

Since the carbon flux computing include data-intensive, computation-intensive, and knowledge-intensive components, scientific workflows defined as an executable description of a scientific process and standard description of data sets offer an opportunity to increase efficiency, reliability and reusability on data computing and sharing. In addition to well management of towers data, it is necessary to provide an efficient data management system to facilitate data archiving, discovery, access and processing of collected data.

In this article, we briefly describe the use of ecoinformatics techniques to develop a flux data computing and sharing system in Taiwan.

The idea of using ecoinformatics techniques comes from contacting with local flux scientists

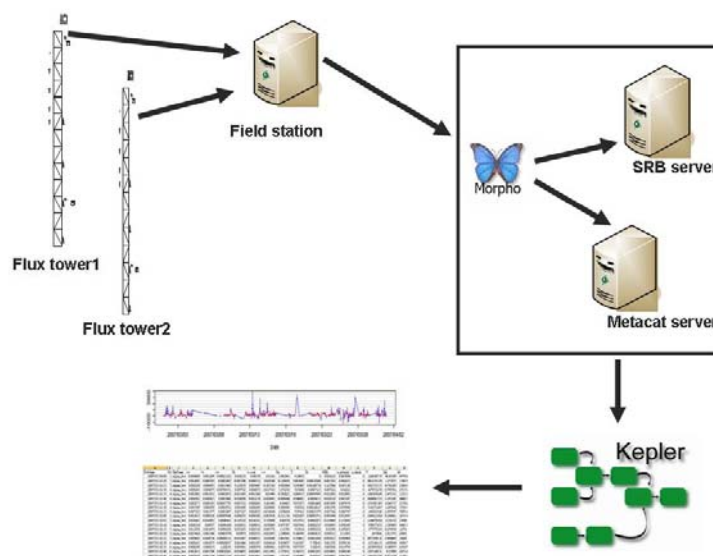

Figure 1. Using EML-based tools for carbon flux data management



on the data management issue. We found that due to no universally accepted method of carbon flux data management has been established, archiving, curating, discovering, retrieving and analyzing data collected are time and man power consumed. Each flux research group has formed their own network and each has developed software to address data management issues. Since 2004, Taiwan Ecological Research Network (TERN) has attempted to collect existing EML-based tools to assemble them as a data management system. Therefore, we believed this system also could be used universally in carbon flux research. We decided to develop this metadata approach flux data management system which started from working with information managers of TERN and the National Dong Hwa University flux research group.

EML is a standard for documenting ecological data that is implemented as a series of XML modules (EML Specification: <http://knb.ecoinformatics.org/software/eml/eml-2.0.1/index.html>). It has already been adopted by several ILTER networks (US LTER, Taiwan Ecological Research Network (TERN), Israel LTER, Mexico LTER, and South African Environmental Observation Network (SAEON)), because tools exist to create, manage, and analyze data using EML. Using this EML-based data management system, a conceptual framework has been developed for flux data management that can be divided into three tiers (Fig. 1).

The first tier deals with datasets and related

information. Data produced by eddy covariance sensors communicating automatically through wired or wireless networks are managed by this tier. In this first tier, all information related to a flux dataset is documented in EML using the Morpho EML editor. The second tier relates to information management. Once metadata and data quality have been described and checked, the metadata are stored in the Metacat system (Java servlet, LDAP authentication, and backend schema-independent database). Data are stored using Storage Resource Broker (SRB). The third tier consists of web service based scientific workflows that allow easy access to the second tier. The Kepler workflow system was adapted for use in this layer.

The use of this EML data management system was applied in Chilan, a TERN site where two flux towers have been set up since 2000. The two towers are equipped with vertical and horizontal wind vectors and the CO₂ mixing ratio at 20 Hz is measured with a sonic anemometer. A desktop computer collects these data. Every 30 minutes, the computer stores the raw data which is downloaded weekly and loaded to a SRB server to be retrieved for analysis. Metadata for these raw data are created and stored in the Metacat. Then, using the Kepler system, five workflows (Fig. 2) are run that search metadata from the Metacat, download data from the SRB, rotate data coordinates, QA/QC the data, and create Web-Pearman-Leuning (WPL) corrections to standardize the flux data calculation process based on each 30 minutes of data collected.

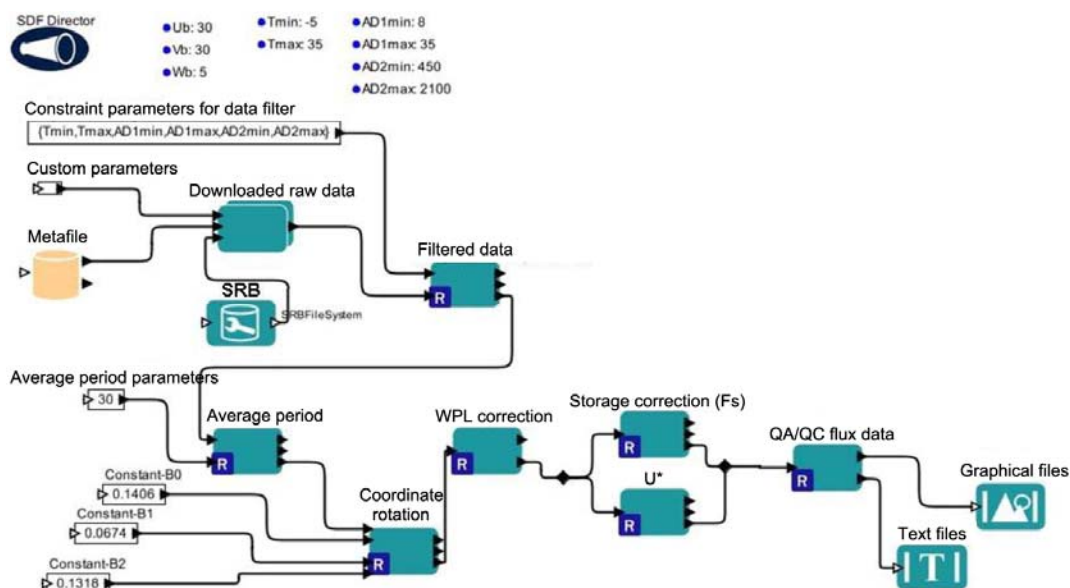

Figure 2. Workflow constructed in Kepler system



Output of the final calculation of all flux data are displayed in a text file which reports all the variables and a graphical file which shows the flux trend of a specific period. These secondary data can be saved locally or remotely. The adaptation of the existing tools based on EML from the flux data management experiment has achieved the goal that analyses of sequential ecological data be accompanied by formal process metadata.

The result shows that Kepler system can be

used to solve data management and computing issues such as complicate process of computing, the lack of software, time consuming on data handling and cleaning and real time data management. In addition, we choose the approach to use metadata as data content description and separate metadata from raw data storage has found a benefit to solve the archiving difficulty of the large volume of flux raw data and can be shared through the distributed operation platform.



AsiaFlux Newsletter
January 2010, Issue No.31

AsiaFlux Secretariat
#533B Science Hall, Yonsei University
262 Seongsanno, Seodaemun-gu,
Seoul 120-749, Korea
Ph: +82-2-2123-7680
Fax:+82-2-312-5691
E-mail: seoul@asiaflux.net
secretary@asiaflux.net

AsiaFlux Newsletter is only available on the
AsiaFlux Website: www.asiaflux.net



I sincerely appreciate all the authors for their contributions to this issue, and I also want to send the special thanks to Mr. Yoo for his generous help. Wish a fruitful 2010 and happy new year for all AsiaFlux members!

The Editor of AsiaFlux Newsletter No. 31

Leiming Zhang

(Chinese Academy of Sciences, China)

The Editor of AsiaFlux Newsletter No. 32 will be
Dr. Poonpipope Kasemsap (Kasetsart University ,
Thailand).